

## FEATURES

- 1.5V to 5.0V Output Voltage Versions
- Guaranteed 250mA Output Current
- Extremely Low Quiescent Current
- Very Low Dropout Voltage
- Reverse Battery Protection
- Extremely Tight Line and Load Regulation
- Very Low Temperature Coefficient
- Current and Thermal Limiting
- Available in TO-92, TO-263, and TO-220 Packages

## APPLICATIONS

- High Efficiency Linear Regulator
- Low Dropout Battery-Powered Regulator

## DESCRIPTION

The LP2954 is a fixed voltage micropower voltage regulator with very low quiescent current (90 $\mu$ A typical at 1mA load) and very low dropout voltage (typically 60mV at light loads and 470mV at 250mA load current). The quiescent current increases only slightly at dropout (120 $\mu$ A typical), which prolongs battery life. The LP2954 with a fixed output is available in the three-lead TO-220, TO-263, and TO-92 packages. Reverse battery protection is provided. The tight line and load regulation (0.04% typical), as well as very low output temperature coefficient make the LP2954 well suited for use as a low-power voltage reference. Output accuracy is guaranteed at both room temperature and over the entire operating temperature range.

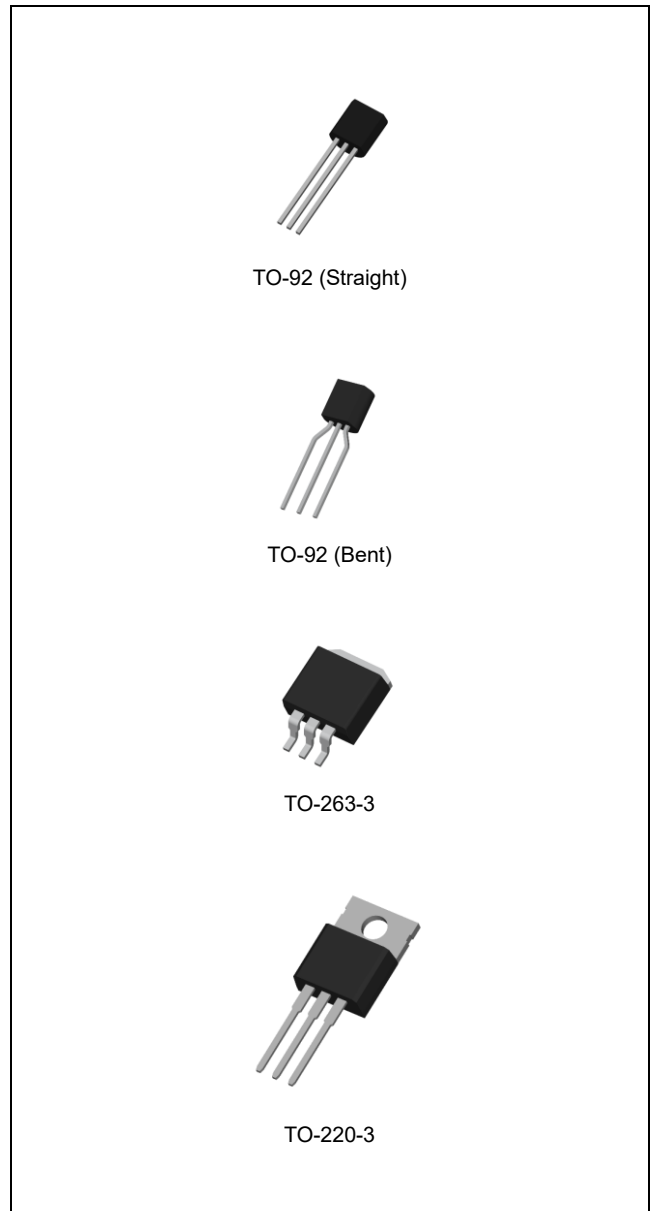

## ORDERING INFORMATION

Device	Package
LP2954-x.x	TO-92 (Straight)
LP2954TA-x.x	TO-92 (Bent)
LP2954R-x.x	TO-263-3L
LP2954T-x.x	TO-220-3L

x.x: Output Voltage

**ABSOLUTE MAXIMUM RATINGS** (Note 1)

CHARACTERISTIC	SYMBOL	MIN	MAX	UNIT
Input Supply Voltage	$V_{IN}$	-20	30	V
Power Dissipation	$P_D$		Limited	
ESD Rating, HBM	-	2000	-	V
Junction Temperature	$T_J$	-40	125	°C
Storage Temperature	$T_{STG}$	-65	150	°C

Note 1. Stresses beyond those listed under *Absolute Maximum Ratings* may cause permanent damage to the device. These are stress ratings only and functional operation of the device at these or any other conditions beyond those indicated under *Recommended Operating Conditions* is not implied. Exposure to absolute-maximum-rated conditions for extended periods may affect device reliability.

**RECOMMENDED OPERATING RATINGS**

CHARACTERISTIC	SYMBOL	MIN	MAX	UNIT
Supply Voltage (Note 2)	$V_{IN}$	2.3	30	V
Junction Temperature	$T_J$	-40	125	°C

Note 2. Recommended minimum  $V_{IN}$  is the greater of 2.3V or  $V_O$  (max) + rated dropout voltage (max) for operating load current.

## ORDERING INFORMATION

VOUT	Package	Order No.	Description	Supplied As	Status
5.0V	TO-92 (Straight)	LP2954-5.0	Straight Lead	Bulk	Active
	TO-92 (Bent)	LP2954TA-5.0	Bent Lead (0.2 In Line Spacing)	Tape & Ammo Pack	Contact Us
	TO-263-3L	LP2954R-5.0		Tape & Reel	Active
	TO-220-3L	LP2954T-5.0		Tube	Active

\* 1.5V to 5.0V output voltages are available upon request by customer

## PIN CONFIGURATION

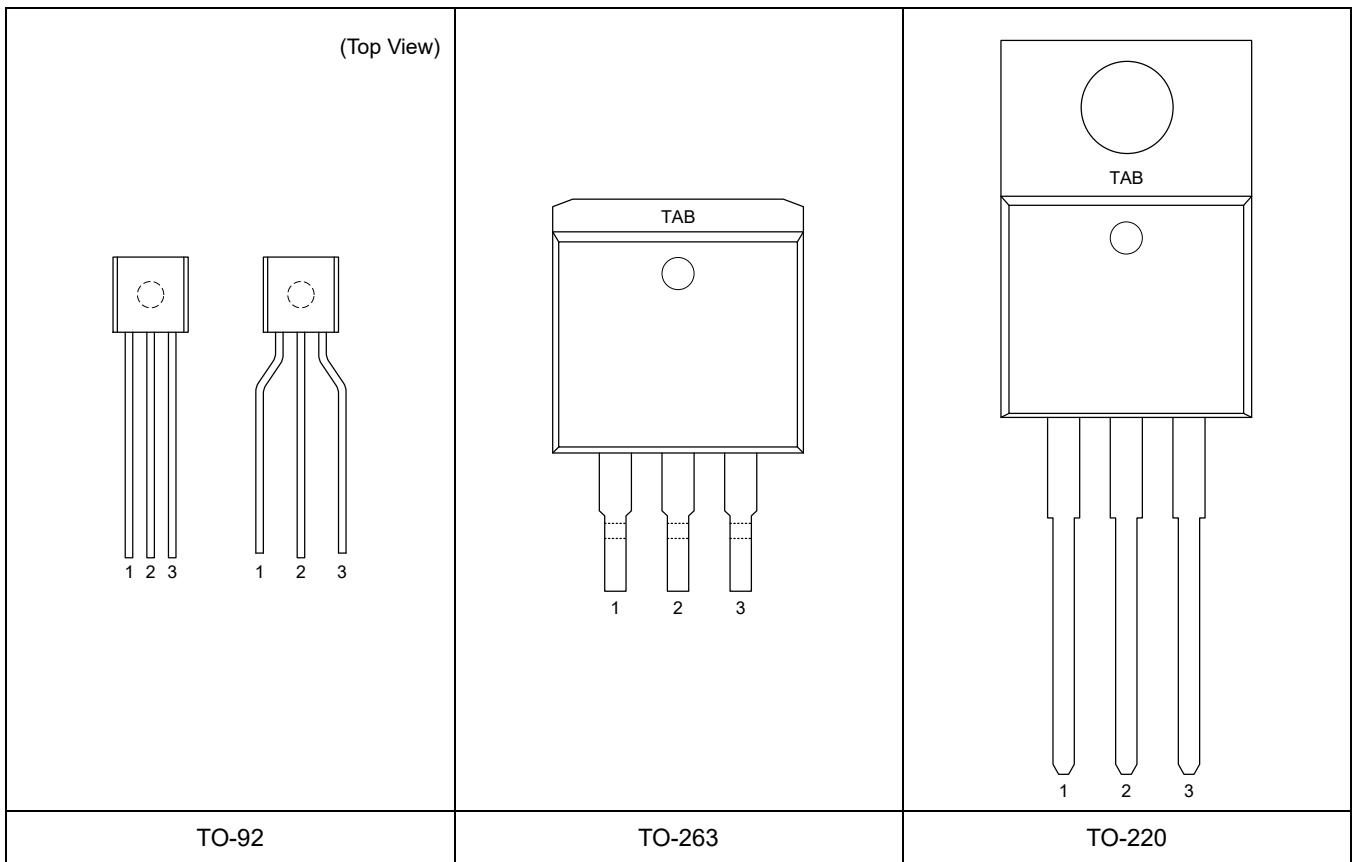

## PIN DESCRIPTION

Pin No.			Pin Name	Pin Function
TO-92	TO-263	TO-220		
3	1	1	IN	Input Voltage
2	2	2	GND	Ground
1	3	3	OUT	Output Voltage
-	TAB	TAB	TAB	Connect to GND. Attached to heatsink for thermal relief for TO-220 package or put a copper plane connected to this pin as a thermal relief for TO-263 package.

## BLOCK DIAGRAM

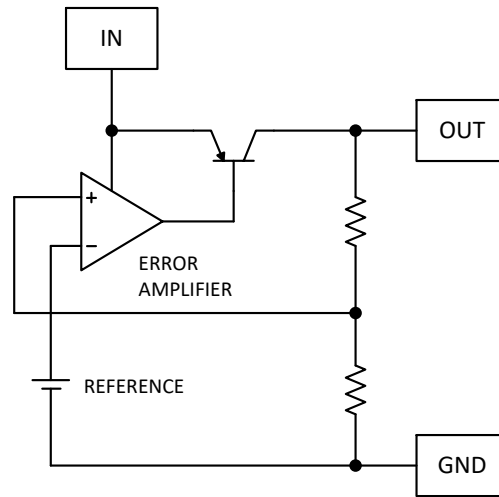

## TYPICAL APPLICATION

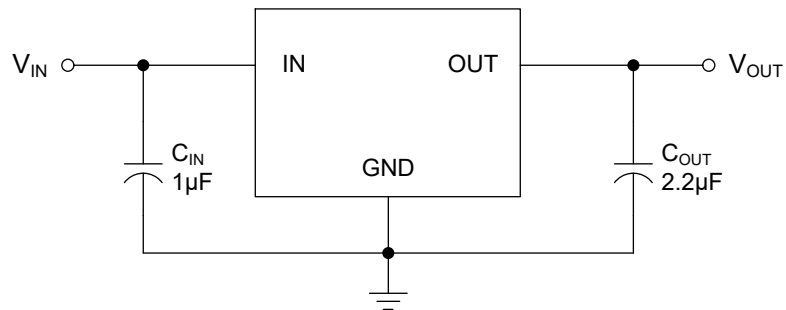

## ELECTRICAL CHARACTERISTICS

Limits in standard typeface are for  $T_J = 25^\circ\text{C}$ , and limits **boldface** type apply over the full operating temperature range. Limits are specified by production testing or correlation techniques using standard Statistical Quality Control (SQC) methods. Unless otherwise noted:  $V_{IN} = V_{OUT} + 1\text{ V}$ ,  $I_L = 1\text{ mA}$ ,  $C_L = 2.2\ \mu\text{F}$

PARAMETER	SYMBOL	TEST CONDITIONS	MIN	TYP	MAX	UNIT
Output Voltage	$V_{OUT}$	$I_L = 1\text{ mA}$	$\times 0.99$ <b><math>\times 0.98</math></b>	$V_{OUT(NOM)}$	$\times 1.01$ <b><math>\times 1.02</math></b>	V
		$1\text{ mA} \leq I_L \leq 250\text{ mA}$	<b><math>\times 0.976</math></b>	$V_{OUT(NOM)}$	<b><math>\times 1.024</math></b>	V
Output Voltage Temperature Coefficient	$\Delta V_{OUT}/\Delta T$	(Note 3)	-	<b>20</b>	<b>150</b>	ppm/ $^\circ\text{C}$
Line Regulation	LNR	$V_{IN} = V_{OUT(NOM)} + 1\text{ V}$ to 30 V	-	0.03	0.20 <b>0.40</b>	%
Load Regulation (Note 4)	LDR	$I_L = 1\text{ mA}$ to 250 mA, $I_L = 0.1\text{ mA}$ to 1 mA	-	0.04	0.20 <b>0.30</b>	%
Dropout Voltage	$V_{DROP}$	$I_L = 1\text{ mA}$	-	60	100 <b>150</b>	mV
		$I_L = 50\text{ mA}$	-	240	300 <b>420</b>	mV
		$I_L = 100\text{ mA}$	-	310	400 <b>520</b>	mV
		$I_L = 250\text{ mA}$	-	470	600 <b>800</b>	mV
Ground Pin Current	$I_{GND}$	$I_L = 1\text{ mA}$	-	90	150 <b>180</b>	$\mu\text{A}$
		$I_L = 50\text{ mA}$	-	1.1	2 <b>2.5</b>	mA
		$I_L = 100\text{ mA}$	-	4.5	6 <b>8</b>	mA
		$I_L = 250\text{ mA}$	-	21	28 <b>33</b>	mA
		$V_{IN} = V_{OUT(NOM)} - 0.5\text{ V}$	-	120	170 <b>210</b>	$\mu\text{A}$
Current Limit	$I_{CL}$	$V_{OUT} = 0\text{ V}$	-	380	500 <b>530</b>	mA
Thermal Regulation	$\Delta V_{OUT}/\Delta P_D$	(Note 5)	-	0.05	0.2	%/W
Output Noise Voltage (10 Hz to 100 kHz)	$e_n$	$I_L = 100\text{ mA}$ , $C_L = 2.2\ \mu\text{F}$	-	400	-	$\mu\text{V}_{RMS}$
		$I_L = 100\text{ mA}$ , $C_L = 33\ \mu\text{F}$	-	260	-	

Note 3. Output voltage temperature coefficient is defined as the worst case voltage change divided by the total temperature range.

Note 4. Low duty cycle pulse testing with Kelvin connections required.

Note 5. Thermal regulation is defined as the change in output voltage at a time T after a change in power dissipation is applied, excluding load or line regulation effects. Specifications are 200mA load pulse at  $V_{IN} = 20\text{V}$  (3W pulse) for  $T=10\text{ms}$ .

**TYPICAL OPERATING CHARACTERISTICS**

T.B.D.

## APPLICATION INFORMATION

T.B.D.

## REVISION NOTICE

The description in this datasheet is subject to change without any notice to describe its electrical characteristics properly.