

NE555 Pulse Generator Module

FEATURES

- NE555 Pulse Generator Module
- Input Voltage Range: 5V to 15V
- Output Voltage: 4.2V to 11.4V
- Max. Output Current: 15mA to 35mA
- Output with LED indication
- Selectable Output Frequency Range

APPLICATIONS

- Adjustable pulse for MCU.
- Adjustable pulse to control circuitry associated.
- Used to drive a stepper motor for generating a square wave drive signal.

DESCRIPTION

The NE555 Pulse Frequency Duty Cycle Adjustable Module Square Wave Signal Generator is 5V square wave signal generator.

APPLICATION GUIDE

It generates a square wave signal used for experimental development. Also, use to drive a stepper motor for generating a square wave drive signal. The output duty cycle can fine-tune. The duty cycle and frequency are not separately adjustable, adjusting the duty cycle will change the frequency.

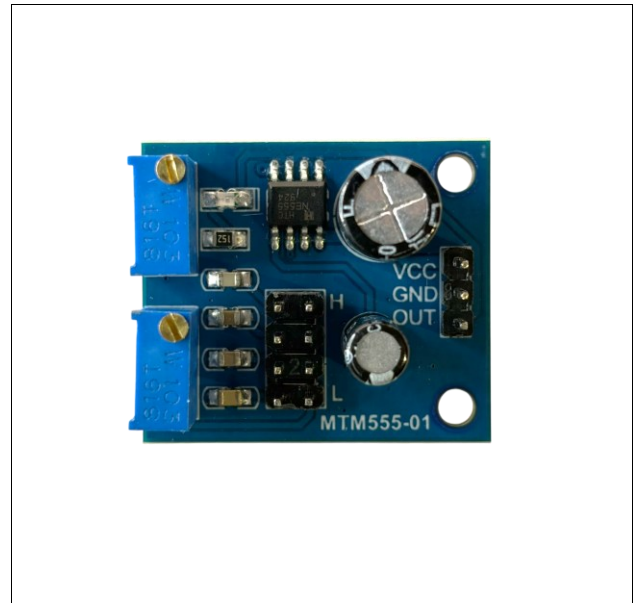

ORDERING INFORMATION

Part Number	MTM555-01
Device	NE555 Pulse Generator Module
Package	Assembled Module (30mm X 26mm)

NE555 Pulse Generator Module

SCHEMATICS

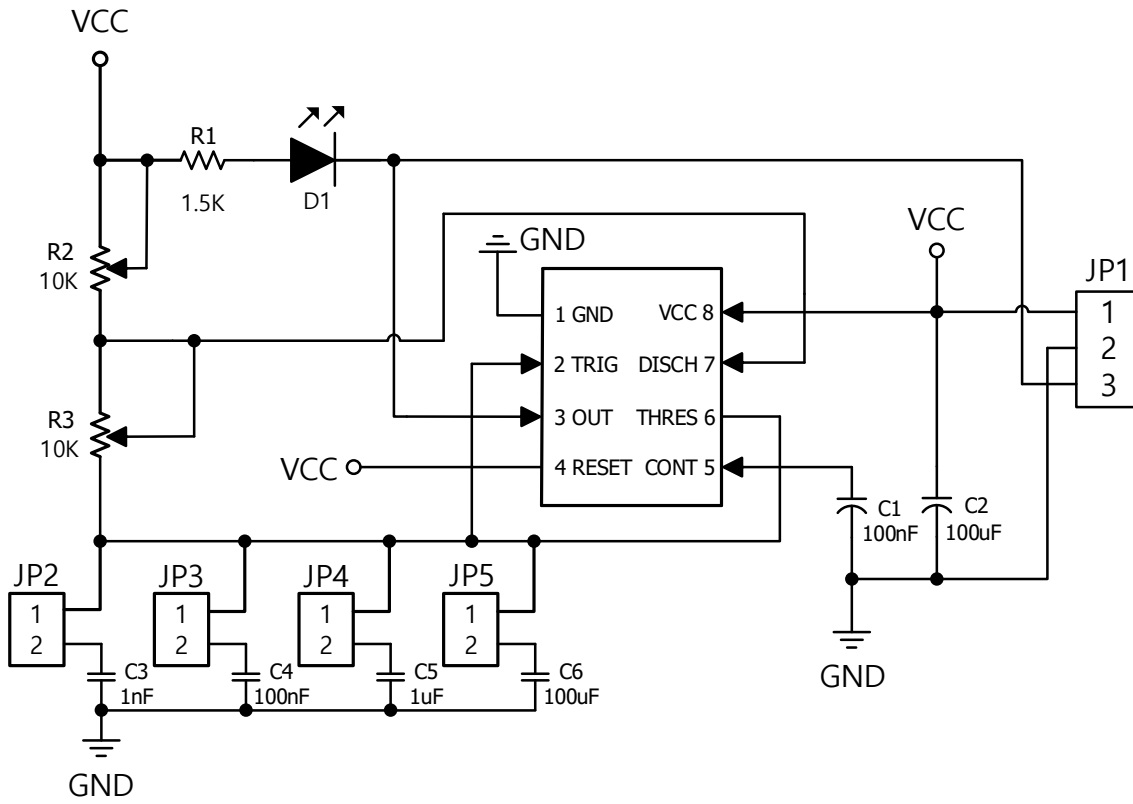

LAYOUT

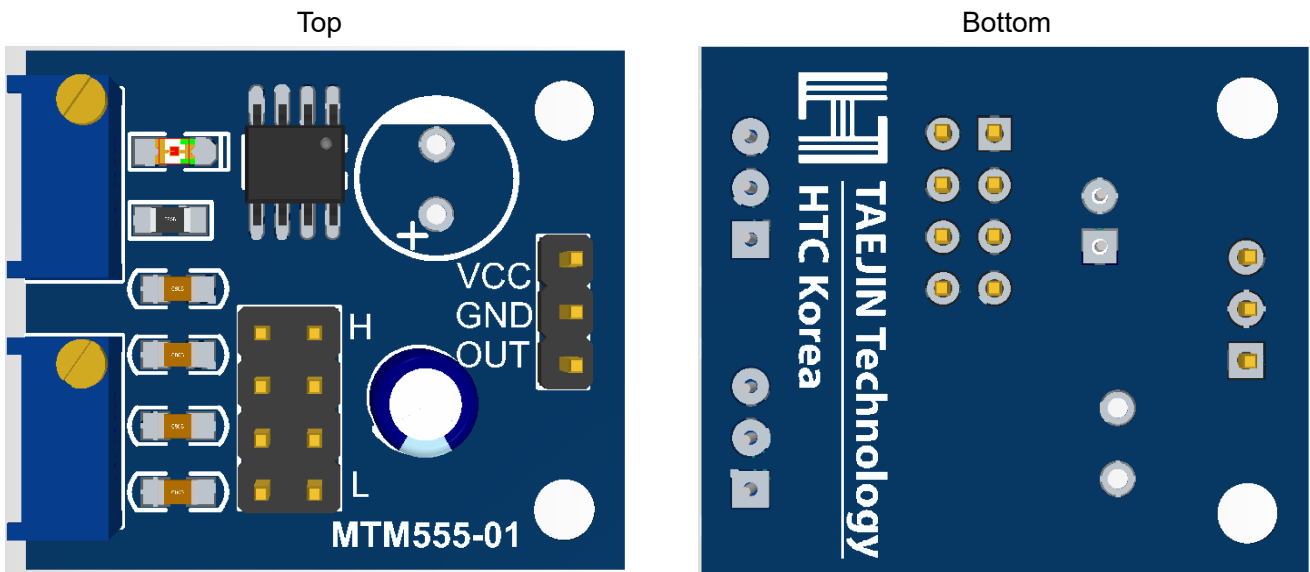

NE555 Pulse Generator Module

PARTS LIST

Name	Description	P/N	Qty.	Distributor
PCB	Printed Circuit Board	FR4 Lead-Free PCB	1	TAEJIN
IC	NE555D, SOP-8	NE555D	1	TAEJIN
Potentiometer	10k Adjustable Potentiometer	3296W	1	Generic
Pin Header	2*4 / 2.54mm pitch	Male Pin Header	1	Generic
Pin Header	1*3 / 2.54mm pitch	Male Pin Header	1	Generic
Jumper	2pin 2.54mm pitch	Jumper Cap	1	Generic
LED	LED for Indicator	LED, Green	1	Generic
Resistor	1.5K Ω Resistor	1.5K Ω 5% Resistor, 1608(0603)	1	Generic
Capacitor	1nF / 16V Capacitor	1nF / 50V Capacitor 2012(0805)	1	Generic
Capacitor	100nF / 16V Capacitor	100nF / 50V Capacitor 2012(0805)	1	Generic
Capacitor	1 μ F / 16V Capacitor	1nF / 16V Capacitor 2012(0805)	1	Generic
Capacitor	100 μ F / 16V Capacitor	100 μ F / 16V Capacitor 2012(0805)	1	Generic
Capacitor	100 μ F Capacitor	100 μ F/50V Electrolytic Capacitor	1	Generic
Capacitor	100nF Capacitor	100nF/50V Electrolytic Capacitor	1	Generic

SIZE INFORMATION

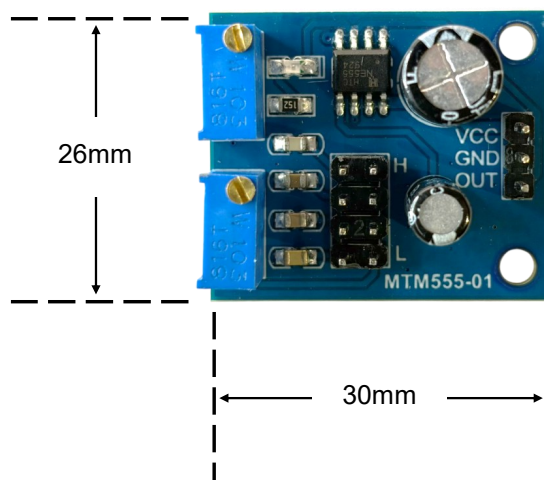

NE555 Pulse Generator Module

PRODUCT IMAGE

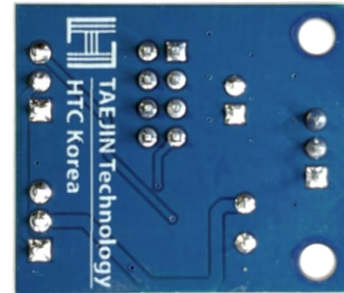
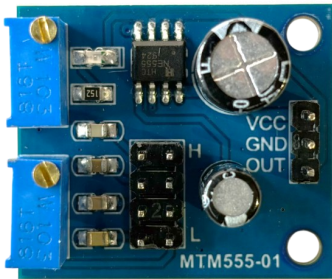

I/O PORT CONFIGURATION AND DESCRIPTION

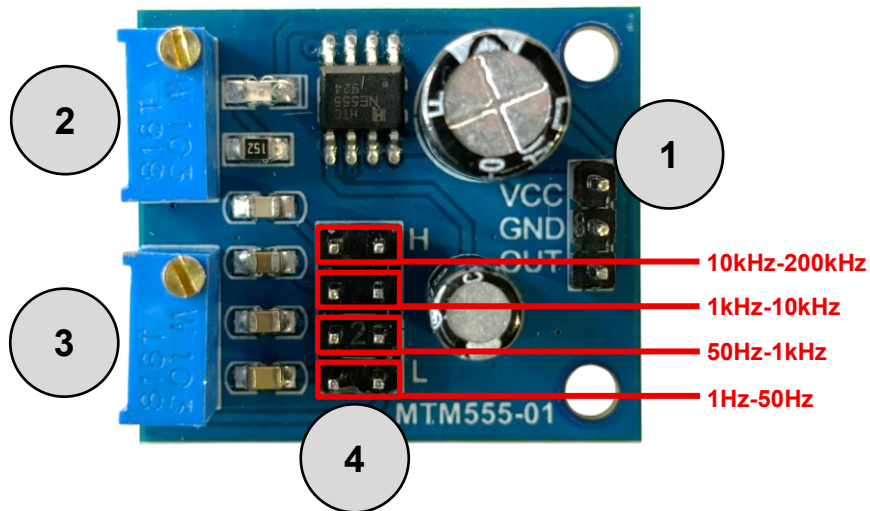

Designator	Port Name	Port Description
1	Vcc / Output Pin	Input 5V to 15V / Output 4.2V to 11.4V
2	Duty Cycle Control Potentiometer	It can control Duty Cycle by tuning Potentiometer
3	Frequency Control Potentiometer	It can control Frequency by tuning Potentiometer
4	Frequency Range Selectable Pin	Selectable Frequency Range by using pin jumper

NE555 Pulse Generator Module

REVISION NOTICE

The description in this datasheet is subject to change without any notice to describe its electrical characteristics properly.

FEATURES

- Exact equivalent in most cases for SE/NE555
- Low Supply Current
- High speed operation – 500KHz guaranteed
- Wide operation supply voltage range - 2V to 18V
- Timing from microseconds through hours
- Operates in both astable and monostable modes
- Adjustable duty cycle
- High output source/sink driver can drive TTL/CMOS

APPLICATION

- Precision timing
- Pulse generation
- Sequential timing
- Time delay generation
- Pulse width modulation
- Pulse position modulation
- Missing Pulse detector

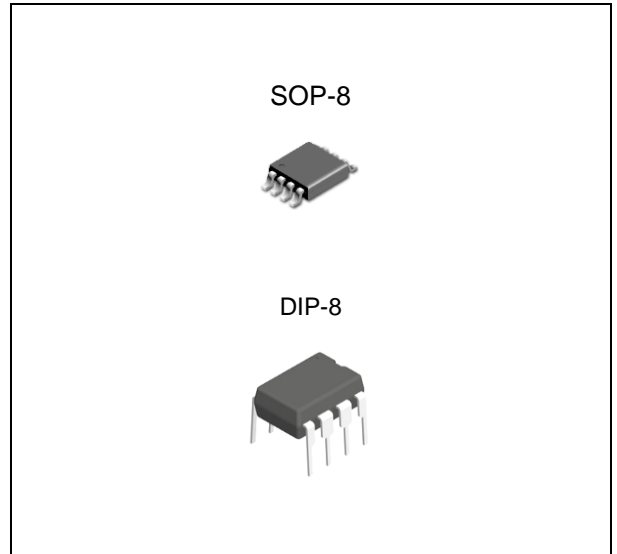

ORDERING INFORMATION

Device	Package
NE555D	SOP-8
NE555N	DIP-8

DESCRIPTION

The NE555 is CMOS RC timers providing significantly improved performance over the standard SE/NE555 and 355 timers, while at the same time being direct replacements for those devices in most applications. Improved parameters include low supply current, wide operating supply voltage range, low THRESHOLD, TRIGGER and RESET currents, no crowbaring of the supply current during output transitions, higher frequency performance and no requirement to decouple CONTROL VOLTAGE for stable operation. Specifically, the NE555 is stable controller capable of producing accurate time delays of frequencies.

ABSOLUTE MAXIMUM RATINGS (Note 1)

CHARACTERISTIC	SYMBOL	MIN.	MAX.	UNIT
Supply Voltage	V_{CC}	0	18	V
Output Current	I_O	-	100	mA
Input Voltage	$V_{TH}, V_{TRIG}, V_{RST}$	-0.3	$V_{CC}+0.3$	V
Storage Temperature Range	T_{STG}	-65	150	°C
Junction Temperature Range	T_J	-20	85	°C

RECOMMENDED OPERATING RATINGS (Note 2)

CHARACTERISTIC	SYMBOL	MIN.	MAX.	UNIT
Supply Voltage	V_{CC}	2	18	V
Operating Junction Temperature Range	$T_{J\ OPR}$	-20	70	°C

ORDERING INFORMATION

Order No.	Package	Description	Supplied As	Status
NE555D	SOP-8	General Purpose Timer	Reel	Active
NE555N	DIP-8	General Purpose Timer	Tube	Active

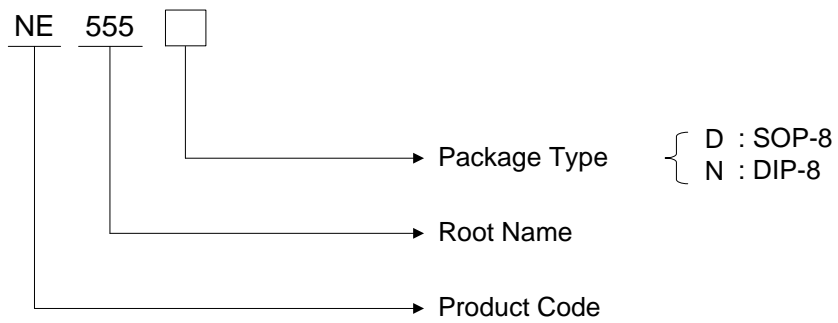

PIN CONFIGURATION

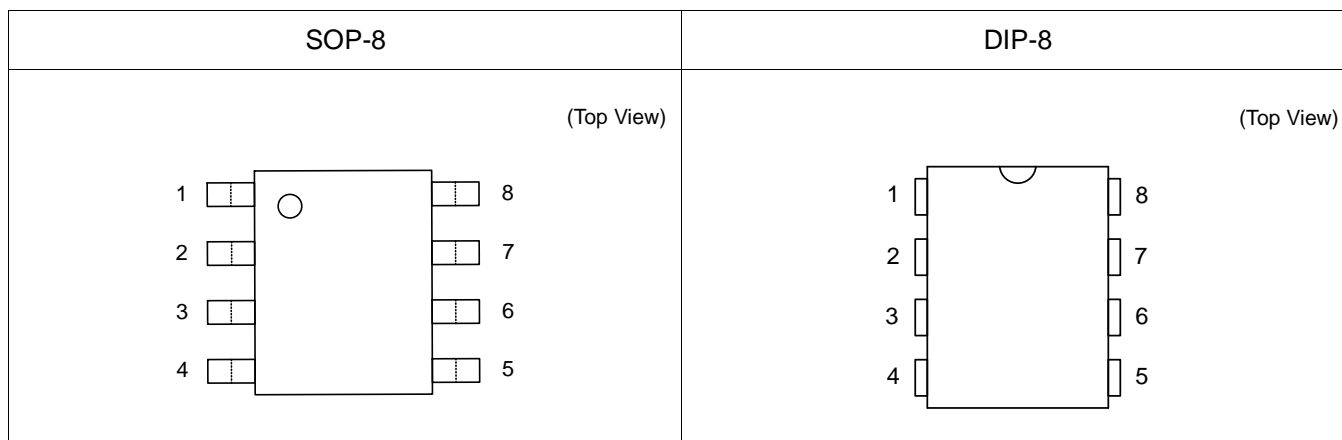

PIN DESCRIPTION

Pin No.	Name	Function
1	GND	Supply ground
2	$\overline{\text{TRIGGER}}$	Start timer input; (Active LOW)
3	OUTPUT	Timer logic level output
4	$\overline{\text{RESET}}$	Timer inhibit input; (Active LOW)
5	CONTROL VOLTAGE	Timing capacitor upper voltage sense input
6	THRESHOLD	Timing capacitor lower voltage sense input
7	DISCHARGE	Timing capacitor discharge output
8	VCC	Supply voltage

FUNCTIONAL DIAGRAM

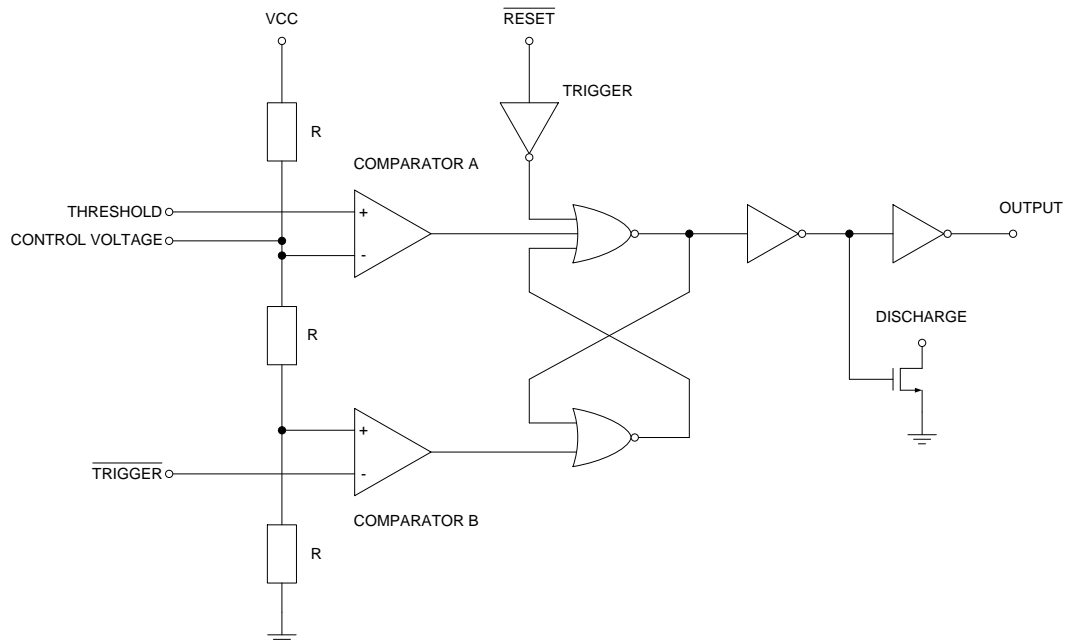

SWITCHING WAVEFORMS

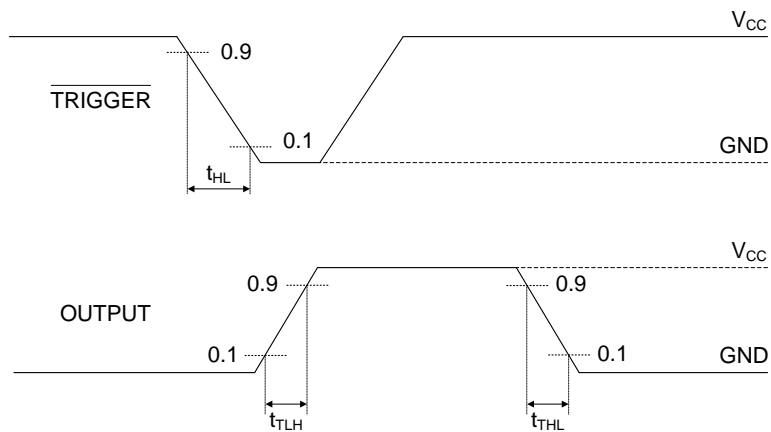

TRUTH TABLE

THRESHOLD	$\overline{\text{TRIGGER}}$	$\overline{\text{RESET}}$	OUTPUT	DISCHARGE
X	X	L	L	ON
$> 2/3V_{CC}$	$> 1/3V_{CC}$	H	L	ON
$< 2/3V_{CC}$	$> 1/3V_{CC}$	H	STABLE	STABLE
X	$< 1/3V_{CC}$	H	H	OFF

ELECTRICAL CHARACTERISTICS (Note 3)

Limits in standard typeface are for $T_J = 25^\circ\text{C}$, and limits in **boldface type** apply over the **full operating temperature range**. $V_{CC}=5\text{V}$, unless otherwise specified.

PARAMETER	SYMBOL	TEST CONDITION	MIN.	TYP.	MAX.	UNIT
DC ELECTRICAL CHARACTERISTICS						
Threshold Voltage	V_{TH}	$V_{CC} = 5\text{V}$	3.2		3.5	V
		$V_{CC} = 15\text{V}$	9.6		10.5	
Trigger Voltage	V_{TRIG}	$V_{CC} = 5\text{V}$	1.55		1.8	V
		$V_{CC} = 15\text{V}$	4.6		5.4	
Reset Voltage	V_{RST}	$V_{CC} = 2\text{V}, 15\text{V}, 18\text{V}$	0.4		1.0	V
Control Voltage	V_{CV}	$V_{CC} = 5\text{V}$	3.2		3.5	V
		$V_{CC} = 15\text{V}$	9.6		10.5	
Output Voltage (Low)	V_{OL}	$V_{CC} = 5\text{V}, I_{OL} = 3.2\text{mA}$			0.4	V
		$V_{CC} = 15\text{V}, I_{OL} = 20\text{mA}$			1.0	
		$V_{CC} = 15\text{V}, I_{OL} = 50\text{mA}$			2.0	
Output Voltage (High)	V_{OH}	$V_{CC} = 5\text{V}, I_{OH} = -0.8\text{mA}$	4.0			V
		$V_{CC} = 15\text{V}, I_{OH} = -0.8\text{mA}$	14.3			
		$V_{CC} = 15\text{V}, I_{OH} = -10\text{mA}$	12.5			
Supply Current	I_{CC}	$V_{CC} = 2\text{V}$			200	μA
		$V_{CC} = 18\text{V}$			300	
AC ELECTRICAL CHARACTERISTICS						
Rise/ Fall Time of Output	t_{THL}, t_{TLH}	$V_{CC} = 5\text{V}, R_L = 10\text{M}\Omega, C_L = 10\text{pF}$		35		ns
					150	
Guaranteed Max Osc Freq.	f_{MAX}	$V_{CC} = 5\text{V}$, astable mode	500			kHz
Initial Accuracy		$R_L = 1$ to $100\text{K}\Omega, C_L = 0.1\mu\text{F}$	5			%
Drift with Temperature	α_f	$V_{CC} = 5\text{V}, R_L = 1$ to $100\text{K}\Omega, C_L = 0.1\mu\text{F}$			0.02	$\%/^\circ\text{C}$
		$V_{CC} = 10\text{V}, R_L = 1$ to $100\text{K}\Omega, C_L = 0.1\mu\text{F}$			0.03	
		$V_{CC} = 15\text{V}, R_L = 1$ to $100\text{K}\Omega, C_L = 0.1\mu\text{F}$			0.06	
Drift with Supply Voltage	Δf	$V_{CC} = 5\text{V}, R_L = 1$ to $100\text{K}\Omega, C_L = 0.1\mu\text{F}$			3	$\%/V$
					6	

Note 1. Exceeding the absolute maximum ratings may damage the device.

Note 2. The device is not guaranteed to function outside its operating ratings.

Note 3. Stresses listed as the absolute maximum ratings may cause permanent damage to the device. These are for stress ratings. Functional operating of the device at these or any other conditions beyond those indicated in the operational sections of the specifications is not implied. Exposure to absolute maximum rating conditions for extended periods may remain possibly to affect device reliability.

Note 4. Parameters are not 100% tested. Majority of all units meet this specification.

APPLICATION INFORMATION

T.B.D.

REVISION NOTICE

The description in this datasheet is subject to change without notice to describe its electrical characteristics properly.